

INTEROPERABILITY AND STANDARDIZATION IN IoT AND CLOUD INTEGRATION

HANI MOHAMMED AL-DUAIS

International Office, Business School, Windesheim University of Applied Sciences, Netherlands.
Email: h.al-duais@windesheim.nl

Dr. SHARAF ALZOUBI

Assistant Professor, Software Engineering Department, College of Computer Sciences and Informatics, Amman Arab University, Amman, Jordan. Email: skalzubi@aau.edu.jo

Dr. YAZEED AL MOAIAD

Associate Professor, Faculty of Computer and Information Technology, MEDIU, Malaysia.
Email: yazeed.alsayed@mediu.edu.my

Dr. WAHEEB ABU-ULBEH

Assistant Professor, Cybersecurity Department, Faculty of Administrative sciences and Informatics, Al-Istiqlal University, Jericho, 10, Palestine. Email: w.abuulbeh@pass.ps

MOHD HAFIZUDDIN BIN IBRAHIM

Department of Electrical Engineering, Politeknik Kuala Terengganu, Malaysia.
Email: hafizuddin@pkt.edu.my

Dr. TS. YOUSEF A. BAKER EL-EBIARY *

Professor, Faculty of Informatics and Computing, UniSZA, Malaysia.

*Corresponding Author Email: yousefelebiary@unisza.edu.my,
ORCID ID: <https://orcid.org/0000-0002-4392-8015>

Abstract

Introduction: The rapid proliferation of Internet of Things (IoT) devices and the widespread adoption of cloud computing have created a dynamic and interconnected digital ecosystem. However, the lack of interoperability and standardization in the integration of IoT and cloud systems poses significant challenges. This research addresses the critical need for a comprehensive understanding of interoperability issues and the establishment of standardized practices to enhance seamless integration. **Problem Statement:** The diverse landscape of IoT devices and cloud platforms has resulted in a fragmented environment where interoperability issues hinder the efficient exchange of data and functionalities. The absence of standardized protocols exacerbates compatibility challenges, leading to suboptimal performance, increased development complexity, and potential security vulnerabilities. Addressing these issues is crucial for realizing the full potential of IoT and cloud integration. **Objective:** This research aims to investigate the current state of interoperability and standardization in the integration of IoT and cloud technologies. The primary objective is to identify challenges, evaluate existing standards and protocols, and propose recommendations for enhancing interoperability and standardization to promote a more cohesive and efficient ecosystem. **Methodology:** The research employs a multi-faceted methodology, including a comprehensive literature review, case studies of existing IoT and cloud integration projects, and unstructured interviews with industry experts. The analysis focuses on identifying common interoperability challenges, assessing existing standards, and evaluating successful integration strategies. This holistic approach ensures a nuanced understanding of the complex landscape surrounding IoT and cloud interoperability. **Results:** The findings of this research highlight the critical challenges hindering interoperability in IoT and cloud integration. Through an in-depth analysis of existing

standards and successful integration cases, the study provides valuable insights into effective strategies for overcoming interoperability barriers. The results contribute to the development of guidelines and recommendations for achieving seamless integration in diverse IoT and cloud environments. Conclusion: In conclusion, the research underscores the pressing need for enhanced interoperability and standardization in IoT and cloud integration. The identified challenges, coupled with the proposed solutions, offer valuable guidance for industry stakeholders, policymakers, and researchers working towards a more interconnected and efficient digital ecosystem. As IoT and cloud technologies continue to evolve, establishing robust standards becomes imperative for unlocking the full potential of these transformative technologies.

Keywords: Interoperability, Standardization, IoT Integration, Cloud Computing, Connectivity Protocols, Digital Ecosystem.

I. INTRODUCTION

In recent years, the proliferation of Internet of Things (IoT) devices and the widespread adoption of cloud computing have revolutionized the way data is generated, processed, and utilized. This convergence has unlocked unprecedented opportunities for innovation and efficiency across various domains, ranging from smart homes and cities to industrial automation and healthcare [1]. However, alongside these advancements, significant challenges have emerged, particularly concerning interoperability and standardization in integrating IoT devices with cloud-based platforms.

Interoperability refers to the ability of diverse systems, devices, or applications to seamlessly exchange and interpret data, regardless of their underlying technologies or architectures [2]. Achieving interoperability is crucial for realizing the full potential of IoT deployments, as it enables disparate devices and systems to communicate, collaborate, and operate cohesively within complex ecosystems. Similarly, standardization plays a pivotal role in establishing uniform protocols, interfaces, and data formats, thereby facilitating seamless integration and interoperability across heterogeneous IoT and cloud environments.

Despite the promising prospects offered by IoT and cloud integration, the absence of universally accepted standards and interoperability frameworks poses significant barriers to scalability, reliability, and security. Incompatibilities between devices, protocols, and platforms often lead to fragmented ecosystems, vendor lock-in, and increased complexity in deployment and management [3]. Moreover, the lack of standardized approaches hampers innovation, stifles market competition, and limits the interoperability between IoT devices and cloud services from different vendors.

Addressing these challenges requires concerted efforts from industry stakeholders, standardization bodies, and research communities to develop and adopt interoperability standards, protocols, and best practices [4]. By establishing common frameworks for device communication, data exchange, and security protocols, stakeholders can promote seamless interoperability and facilitate the integration of diverse IoT devices with cloud-based platforms [5]. Furthermore, promoting open standards and interoperable solutions fosters interoperability, encourages collaboration, and accelerates innovation across the IoT and cloud ecosystem.

The rapid expansion of the Internet of Things (IoT) and the widespread adoption of cloud computing have ushered in an era of unprecedented connectivity and digitization [6]. This dynamic landscape promises innovative solutions across various domains, from smart homes and healthcare to industrial automation and smart cities [7]. However, amidst this proliferation of interconnected devices and services, interoperability remains a significant challenge.

The integration of IoT devices with cloud platforms forms the backbone of many modern applications, enabling seamless data exchange, real-time analytics, and intelligent decision-making [8]. Yet, the lack of standardized practices and interoperable frameworks poses formidable obstacles to achieving the full potential of this integration.

The diverse array of IoT devices and cloud platforms contributes to a fragmented ecosystem where interoperability issues impede efficient communication and collaboration [9]. Without universally accepted protocols and standards, compatibility challenges arise, leading to suboptimal performance, increased development complexity, and potential security vulnerabilities [10]. As a result, realizing the transformative benefits of IoT and cloud integration becomes increasingly difficult.

This research endeavors to delve into the intricacies of interoperability and standardization within the realm of IoT and cloud technologies. By examining existing challenges, evaluating established standards, and proposing recommendations, the aim is to pave the way for a more cohesive and efficient digital ecosystem.

A multi-faceted approach is adopted to comprehensively address the research objectives. This includes an extensive review of relevant literature, in-depth analysis of case studies from existing IoT and cloud integration projects, and unstructured interviews with industry experts. By triangulating insights from diverse sources, a nuanced understanding of the complexities surrounding interoperability is achieved.

The findings of this research shed light on the critical challenges impeding interoperability in IoT and cloud integration. Through rigorous examination of existing standards and successful integration strategies, valuable insights are gleaned, offering pathways to overcome interoperability barriers. These results serve as a foundation for the development of guidelines and recommendations aimed at fostering seamless integration in diverse IoT and cloud environments.

The research underscores the imperative for enhanced interoperability and standardization in IoT and cloud integration. By addressing the identified challenges and proposing viable solutions, stakeholders across industries stand to benefit, unlocking the transformative potential of these technologies. As IoT and cloud ecosystems continue to evolve, establishing robust standards remains paramount for driving innovation and realizing societal impact.

II. LITERATURE REVIEW

In recent years, the integration of Internet of Things (IoT) devices with cloud computing platforms has emerged as a promising paradigm to leverage the potential of both technologies synergistically. This integration offers immense opportunities for various domains including smart cities, healthcare, agriculture, manufacturing, and transportation, among others [11]. However, achieving seamless interoperability and standardization between IoT devices and cloud systems remains a critical challenge that requires careful consideration.

Interoperability in IoT and Cloud Integration:

Interoperability in the context of IoT and cloud integration refers to the ability of diverse IoT devices and cloud platforms to communicate, exchange data, and interoperate seamlessly. Achieving interoperability is crucial for enabling efficient data flow, interoperable services, and unified management across heterogeneous IoT devices and cloud environments. Several studies have highlighted the significance of interoperability for realizing the full potential of IoT and cloud integration [12,13], see Figure 1 [14].

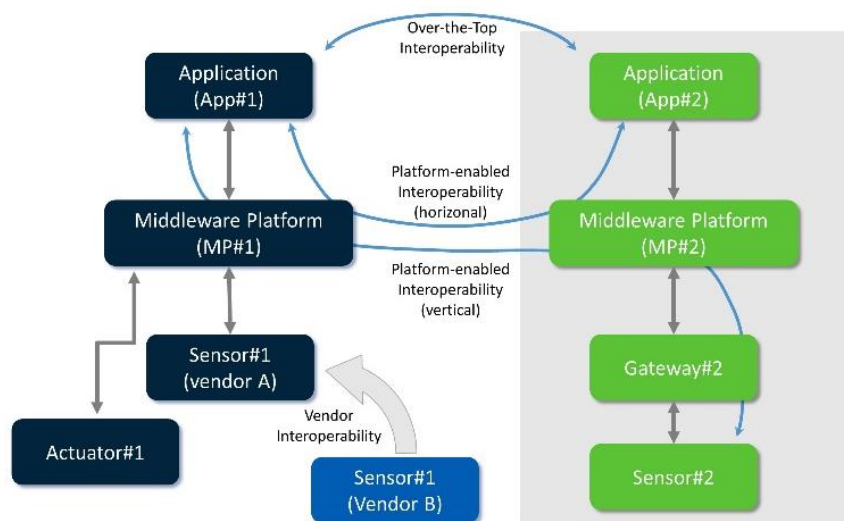

Fig 1: IoT and Cloud Integration

One of the primary challenges in achieving interoperability is the diverse nature of IoT devices, which vary in terms of communication protocols, data formats, and interfaces. This diversity introduces complexity in integrating heterogeneous devices into a unified ecosystem. Standardization efforts aim to address this challenge by defining common protocols, data models, and communication standards that facilitate interoperability among IoT devices and cloud platforms [15, 16].

Standardization in IoT and Cloud Integration:

Standardization plays a pivotal role in enabling seamless communication and integration between IoT devices and cloud systems. Various standardization bodies and

consortia such as the Institute of Electrical and Electronics Engineers (IEEE), International Organization for Standardization (ISO), and the Internet Engineering Task Force (IETF) have been actively involved in developing standards and protocols for IoT and cloud interoperability.

For instance, the IEEE 802.15.4 standard defines the physical and medium access control layers for low-rate wireless personal area networks (LR-WPANs), which are commonly used in IoT applications. Similarly, the ISO/IEC 27000 series provides guidelines and best practices for securing IoT devices and data in cloud environments. These standards contribute to establishing common frameworks and protocols that facilitate interoperability and compatibility among diverse IoT devices and cloud platforms [17, 18].

Challenges and Future Directions:

Despite the progress in standardization efforts, several challenges persist in achieving seamless interoperability and standardization in IoT and cloud integration. These challenges include [19]:

- 1. Heterogeneity:** The continued proliferation of IoT devices with diverse capabilities, protocols, and communication technologies complicates interoperability efforts.
- 2. Security and Privacy:** Ensuring robust security and privacy mechanisms is essential to protect sensitive data transmitted between IoT devices and cloud platforms.
- 3. Scalability:** As the number of connected IoT devices grows exponentially, scalability becomes a key consideration in designing interoperable and standardized solutions.

Addressing these challenges requires interdisciplinary research efforts spanning areas such as networking, security, data management, and standardization. Future research directions may include the development of lightweight protocols for resource-constrained IoT devices, advancements in secure communication protocols, and the establishment of unified frameworks for managing and orchestrating IoT-cloud interactions [20].

Interoperability and standardization are crucial aspects of IoT and cloud integration, enabling seamless communication, data exchange, and interoperable services. While significant progress has been made in standardization efforts, ongoing research is needed to address emerging challenges and realize the full potential of IoT and cloud integration in diverse application domains.

III. IoT AND CLOUD INTEGRATION: CONCEPTS AND CHALLENGES

1. Definition of IoT and Cloud Integration [21, 22]:

IoT (Internet of Things) refers to the network of interconnected physical devices that are embedded with sensors, software, and other technologies, enabling them to collect and exchange data over the internet. These devices can range from everyday objects like household appliances to sophisticated industrial machinery.

Cloud Integration involves the seamless connection and interaction between IoT devices and cloud computing resources. It enables IoT devices to transmit data to cloud platforms for storage, processing, and analysis, as well as receive commands and updates from the cloud.

2. Key Components and Technologies Involved [23, 24]:

- a) **IoT Devices:** These are the physical objects equipped with sensors, actuators, and connectivity features such as Wi-Fi, Bluetooth, or cellular communication.
- b) **Cloud Platforms:** Services provided by cloud computing providers, offering storage, processing, and analytics capabilities. Examples include Amazon Web Services (AWS), Microsoft Azure, and Google Cloud Platform (GCP).
- c) **Communication Protocols:** Various protocols are used for data transmission between IoT devices and cloud platforms, including MQTT (Message Queuing Telemetry Transport), HTTP (Hypertext Transfer Protocol), and CoAP (Constrained Application Protocol).
- d) **Middleware:** Software components that facilitate communication and data management between IoT devices and cloud services. They handle tasks such as data normalization, protocol translation, and device management.

3. Challenges Posed by Heterogeneous Devices and Platforms [25, 26]:

- a) **Device Diversity:** IoT ecosystems consist of diverse devices from different manufacturers, each with its own communication protocols, data formats, and compatibility issues.
- b) **Connectivity:** Ensuring reliable connectivity between IoT devices and cloud services, especially in environments with limited bandwidth or intermittent network coverage.
- c) **Security:** Securing data transmission and storage to protect sensitive information from unauthorized access, data breaches, and cyber-attacks.
- d) **Scalability:** Managing large-scale deployments of IoT devices and accommodating growing volumes of data generated by these devices.

4. Impact of Interoperability and Standardization on Integration Efforts [27, 28]:

- a) **Interoperability:** Establishing interoperability standards allows different IoT devices and cloud platforms to communicate and interact seamlessly, regardless of their underlying technologies. This simplifies integration efforts and promotes compatibility across diverse ecosystems.
- b) **Standardization:** Adopting industry-wide standards for communication protocols, data formats, and security protocols enhances interoperability, streamlines development processes, and facilitates the creation of interoperable IoT solutions.

c) Open-Source Initiatives: Open-source projects and initiatives play a crucial role in driving interoperability and standardization efforts within the IoT ecosystem. They promote collaboration, innovation, and the development of reusable components and frameworks.

IV. INTEROPERABILITY IN IoT AND CLOUD INTEGRATION

1. Definition and Significance of Interoperability:

Definition: Interoperability refers to the ability of different systems, devices, or applications to communicate, exchange data, and operate in conjunction with one another effectively, without the need for special effort from the user, see Figure 2 [29].

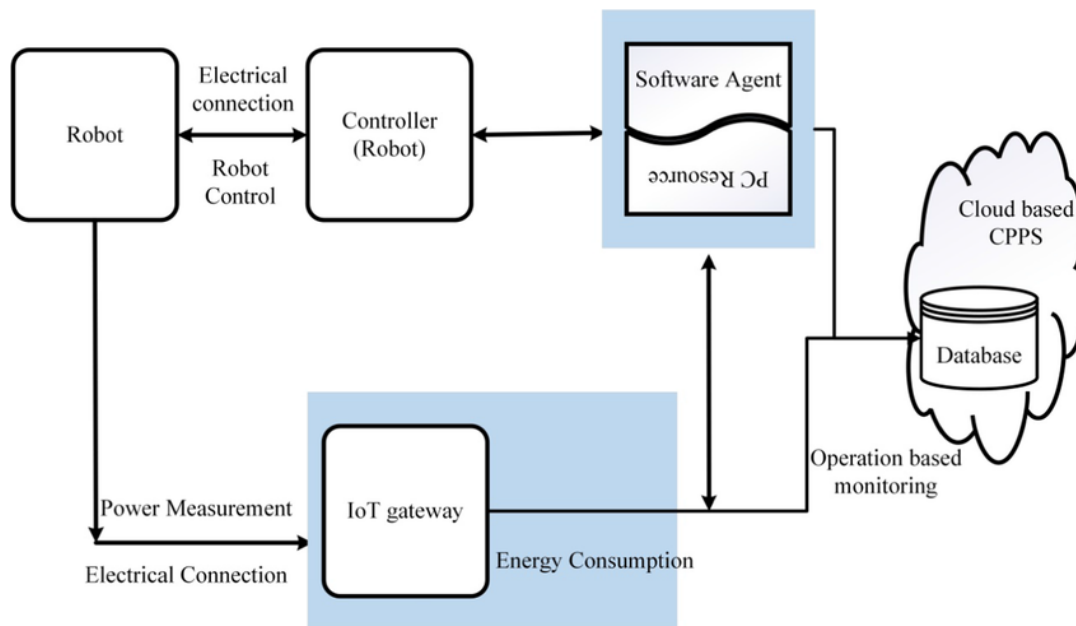

Fig 2: IoT and Cloud Integration

In the context of IoT and cloud integration, interoperability ensures that various IoT devices, sensors, gateways, and cloud platforms can seamlessly interact and share data, regardless of their underlying technologies, protocols, or manufacturers.

Significance: Interoperability plays a pivotal role in unlocking the full potential of IoT and cloud integration by enabling [30, 31]:

- **Scalability:** Interoperable systems can easily accommodate the addition of new devices or services without requiring extensive modifications or custom integrations.
- **Efficiency:** Seamless communication between IoT devices and cloud platforms enhances operational efficiency by streamlining data exchange and automating processes.

- **Innovation:** Interoperability fosters innovation by facilitating the development of diverse IoT ecosystems where devices from different vendors can collaborate and leverage each other's capabilities.
- **Cost-effectiveness:** Standardized interoperability reduces development costs and time-to-market for IoT solutions by promoting the reuse of existing components and technologies.

2. Standards and Protocols Facilitating Interoperability:

Several standards and protocols are instrumental in facilitating interoperability between IoT devices and cloud platforms. Some key ones include [32-34]:

- **MQTT (Message Queuing Telemetry Transport):** A lightweight messaging protocol ideal for IoT applications due to its low bandwidth usage and publish-subscribe architecture.
- **CoAP (Constrained Application Protocol):** Designed for resource-constrained IoT devices, CoAP enables communication between devices and cloud servers over constrained networks, such as those using UDP.
- **HTTP (Hypertext Transfer Protocol):** Widely used for communication between web clients and servers, HTTP is also utilized in IoT applications for accessing cloud services and APIs.
- **OPC UA (Open Platform Communications Unified Architecture):** A standard for industrial automation that ensures interoperability between industrial IoT devices and cloud systems.
- **IEEE 802.15.4:** A standard for low-rate wireless personal area networks (LR-WPANs), providing the physical layer and MAC layer specifications for IoT device communication.
- **IoTivity and AllJoyn:** Frameworks aimed at enabling interoperability and communication between diverse IoT devices and cloud platforms, particularly in the consumer IoT domain.

3. Interoperability Challenges and Solutions in IoT and Cloud Integration [35-39]:

Challenges:

- **Heterogeneity:** IoT ecosystems comprise devices with diverse capabilities, communication protocols, and data formats, posing challenges for seamless interoperability.
- **Security:** Ensuring secure communication and data exchange between IoT devices and cloud platforms without compromising data integrity, confidentiality, or availability is a significant challenge.

- **Scalability:** As IoT deployments grow in scale, managing interoperability becomes increasingly complex, requiring robust solutions to support large-scale device connectivity.
- **Legacy Systems:** Integration with legacy IoT devices or cloud platforms that lack standardized interfaces can hinder interoperability and require custom integration efforts.

Solutions:

- **Adoption of Standards:** Embracing widely accepted standards and protocols promotes interoperability by providing common frameworks for device communication and data exchange.
- **Middleware Solutions:** Middleware platforms and gateways can bridge the gap between heterogeneous IoT devices and cloud systems by translating between different protocols and data formats.
- **APIs and SDKs:** Providing well-documented APIs and software development kits (SDKs) simplifies integration efforts for developers, enabling them to build interoperable IoT applications more efficiently.
- **Security Measures:** Implementing robust security measures, such as encryption, authentication, and access control, helps mitigate security risks associated with interoperable IoT and cloud systems.
- **Interoperability Testing:** Rigorous testing of interoperability between IoT devices and cloud platforms ensures compatibility and reliability, helping identify and address integration issues early in the development lifecycle.

V. STANDARDIZATION IN IoT AND CLOUD INTEGRATION

- 1. Role of Standardization in Ensuring Seamless Integration:** Standardization plays a crucial role in ensuring seamless integration between IoT (Internet of Things) devices and cloud platforms. It establishes common protocols, formats, and communication methods that enable interoperability among diverse devices and platforms. Without standardization, the integration process becomes complex, leading to compatibility issues, security vulnerabilities, and increased development costs [40]. By adhering to standardized protocols, devices can communicate effectively with cloud services, share data securely, and enable smooth interoperability, ultimately enhancing the overall functionality and reliability of IoT systems.
- 2. Overview of Relevant Standards Bodies and Organizations:** Several standards bodies and organizations are actively involved in developing and promoting standards for IoT and cloud integration.

Some of the key ones include [41, 42]:

- **IEEE (Institute of Electrical and Electronics Engineers):** Develops standards for various aspects of IoT, including communication protocols, security, and data formats.
 - **IETF (Internet Engineering Task Force):** Responsible for developing and maintaining Internet standards, including those related to IoT communication protocols such as MQTT (Message Queuing Telemetry Transport) and CoAP (Constrained Application Protocol).
 - **ISO (International Organization for Standardization):** Publishes standards for IoT-related areas such as cybersecurity, data management, and interoperability.
 - **ETSI (European Telecommunications Standards Institute):** Develops standards for IoT networking technologies, including cellular IoT and LPWAN (Low Power Wide Area Network) protocols.
 - **OMG (Object Management Group):** Focuses on standards for IoT middleware and interoperability frameworks.
 - **Open Connectivity Foundation (OCF):** Develops open standards for IoT interoperability, including device discovery, communication, and security.
- 3. Comparison of Different IoT and Cloud Integration Standards:** Various standards exist for IoT and cloud integration, each catering to specific requirements and use cases. Some of the commonly used standards include [43,44]:
- **MQTT (Message Queuing Telemetry Transport):** Lightweight messaging protocol ideal for IoT communication due to its low bandwidth and low power consumption characteristics.
 - **CoAP (Constrained Application Protocol):** Designed for resource-constrained IoT devices, CoAP enables efficient communication over UDP (User Datagram Protocol).
 - **HTTP (Hypertext Transfer Protocol):** Widely used for cloud integration, HTTP provides a standard for communication between IoT devices and web servers.
 - **AMQP (Advanced Message Queuing Protocol):** Supports reliable messaging between IoT devices and cloud platforms, facilitating asynchronous communication.
 - **DDS (Data Distribution Service):** Suitable for real-time data distribution in IoT systems, DDS provides a standardized middleware platform for device communication.

4. Adoption Challenges and Strategies for Promoting Standardization: Despite the benefits of standardization, adoption can face several challenges, including [45,46]:

- **Fragmentation:** The proliferation of diverse standards and protocols can lead to fragmentation, hindering interoperability and complicating integration efforts.
- **Legacy Systems:** Compatibility issues with legacy IoT devices and cloud platforms may arise when transitioning to standardized protocols.
- **Cost and Complexity:** Implementing standard protocols and ensuring compliance can incur additional costs and complexities for IoT developers and manufacturers.

To promote standardization and address these challenges, the following strategies can be employed [47,48]:

- **Collaboration:** Encourage collaboration among standards bodies, industry stakeholders, and technology providers to develop unified standards and address interoperability issues.
- **Education and Awareness:** Increase awareness among IoT developers, manufacturers, and end-users about the benefits of standardization and the importance of adopting standardized protocols.
- **Incentives:** Offer incentives such as certification programs, grants, or subsidies to encourage adoption of standardized protocols and compliance with established standards.
- **Open-Source Initiatives:** Support open-source initiatives that promote the development and adoption of standardized protocols, fostering innovation and collaboration within the IoT ecosystem.
- **Regulatory Measures:** Implement regulatory frameworks or industry guidelines that mandate compliance with recognized standards for IoT and cloud integration, ensuring a level playing field and driving widespread adoption.

VI. BEST PRACTICES AND GUIDELINES

1. Recommended practices for achieving interoperability:

Interoperability is crucial for seamless communication and data exchange between IoT devices and cloud services. Some best practices include [49,50]:

- **Standardization:** Adopt industry-standard protocols and formats such as MQTT, CoAP, or AMQP for communication between devices and cloud platforms. This ensures compatibility across different systems.
- **API Design:** Develop well-defined APIs (Application Programming Interfaces) for interacting with IoT devices and cloud services. RESTful APIs are commonly used due to their simplicity and flexibility.

- **Data Formats:** Use standardized data formats like JSON or XML to represent and exchange information between devices and the cloud. This simplifies data processing and interpretation by different systems.
- **Security Measures:** Implement robust security mechanisms, including encryption, authentication, and access control, to safeguard data transmitted between IoT devices and the cloud.

2. Guidelines for selecting and implementing standards:

Choosing the right standards is essential for ensuring compatibility and interoperability in IoT and cloud integration. Some guidelines include [51,52]:

- **Industry Adoption:** Prioritize standards that are widely adopted within the IoT and cloud computing industries. This reduces the risk of vendor lock-in and promotes interoperability.
- **Openness:** Prefer open standards over proprietary ones to foster collaboration and innovation within the ecosystem. Open standards are typically more flexible and vendor-neutral.
- **Scalability:** Assess the scalability of standards to accommodate the growing number of IoT devices and the increasing volume of data generated. Standards should support large-scale deployments without compromising performance.
- **Future Compatibility:** Consider the long-term viability of standards and their ability to adapt to evolving technologies and requirements. Choose standards that offer backward compatibility and allow for easy upgrades.

3. Strategies for managing compatibility and scalability:

Managing compatibility and scalability requires a proactive approach to infrastructure design and management. Some strategies include [53,54]:

- **Modular Architecture:** Design IoT and cloud systems with a modular architecture that allows components to be easily replaced or upgraded without disrupting the entire system. This facilitates scalability and future expansion.
- **Horizontal Scaling:** Implement horizontal scaling techniques such as load balancing and auto-scaling to distribute workload across multiple servers or instances. This ensures consistent performance as the system grows.
- **Resource Management:** Monitor resource usage (e.g., CPU, memory, bandwidth) and optimize resource allocation to maximize efficiency and scalability. This may involve implementing resource pooling and dynamic resource provisioning mechanisms.
- **Compatibility Testing:** Conduct thorough compatibility testing to ensure that IoT devices and cloud services work seamlessly together. This includes testing interoperability with different devices, platforms, and configurations.

4. Considerations for future-proofing integration solutions:

Future-proofing integration solutions involves anticipating and adapting to changes in technology, standards, and business requirements. Some considerations include [55,56]:

- **Flexibility:** Design systems with flexibility in mind to accommodate future changes and innovations. This may involve using modular components, open standards, and scalable architectures.
- **Scalability:** Plan for future growth by designing scalable architectures that can easily accommodate an increasing number of devices and users. This includes adopting scalable cloud services and architectures.
- **Interoperability:** Prioritize interoperability by choosing standards and protocols that are likely to remain relevant and widely adopted in the future. This reduces the risk of compatibility issues as technology evolves.
- **Continuous Improvement:** Continuously monitor and evaluate the integration solution to identify areas for improvement and optimization. This may involve incorporating feedback from users, tracking industry trends, and leveraging new technologies.

VII. CASE STUDIES AND EXAMPLES

Integrating IoT (Internet of Things) devices with cloud platforms has become increasingly common in various industries, leading to numerous case studies and examples showcasing both successful implementations and challenges faced along the way.

Real-World Examples of IoT and Cloud Integration Projects:

1. **Smart Cities:** Cities around the world are implementing IoT sensors to monitor and manage various aspects of urban life, such as traffic flow, air quality, waste management, and energy consumption. These sensors collect data in real-time and transmit it to cloud platforms for analysis and decision-making [57]. For example, Barcelona's "Smart City" initiative utilizes IoT devices to optimize services like parking, street lighting, and waste management, all integrated with cloud-based analytics platforms.
2. **Industrial IoT (IIoT):** In manufacturing and industrial settings, IoT devices are deployed to monitor equipment health, track inventory, and optimize production processes. These devices generate vast amounts of data, which are sent to cloud platforms for analysis and predictive maintenance [58]. For instance, General Electric's Predix platform integrates IoT sensors on industrial machinery to predict equipment failures and optimize maintenance schedules, ultimately reducing downtime and increasing efficiency.

3. Healthcare: IoT devices are revolutionizing healthcare by enabling remote patient monitoring, medication adherence tracking, and personalized treatment plans. For example, wearable devices like smartwatches and fitness trackers collect health data from patients and transmit it to cloud-based healthcare platforms [59]. Companies like Philips Healthcare have developed IoT-enabled medical devices that connect patients with healthcare providers, allowing for real-time monitoring and early intervention.

Lessons Learned and Insights Gained from Successful Implementations [60,61]:

- 1. Scalability:** Successful IoT and cloud integration projects prioritize scalability from the outset. This involves designing architectures and selecting technologies that can accommodate the growing volume of IoT data without sacrificing performance or reliability. Cloud platforms offer scalability features such as auto-scaling and elastic compute resources, allowing infrastructure to adapt to changing demand seamlessly.
- 2. Data Security and Privacy:** Protecting sensitive IoT data from unauthorized access and ensuring compliance with regulations (such as GDPR or HIPAA) are critical considerations. Successful implementations implement robust security measures, including encryption, access control, and device authentication mechanisms. Additionally, data anonymization techniques may be employed to preserve privacy while still extracting valuable insights from IoT data.
- 3. Interoperability and Standards:** Integrating diverse IoT devices and systems from different vendors can be challenging due to compatibility issues and proprietary protocols. Successful implementations adhere to industry standards and protocols (such as MQTT, CoAP, or OPC UA) to ensure interoperability and seamless communication between devices and cloud platforms. Additionally, employing middleware solutions or IoT platforms that support multiple protocols can simplify integration efforts.

Challenges Encountered and Strategies for Overcoming Them [62,63]:

- 1. Connectivity Issues:** IoT devices may encounter connectivity issues due to network outages, signal interference, or geographical constraints. To address this challenge, redundant network connections and communication protocols can be employed to ensure reliable data transmission. Edge computing solutions may also be utilized to process data locally and reduce reliance on continuous cloud connectivity.
- 2. Data Volume and Complexity:** The sheer volume and complexity of IoT data pose challenges for storage, processing, and analysis. Implementations may struggle to extract actionable insights from the vast amounts of raw data generated by IoT devices. Strategies for overcoming this challenge include implementing data filtering and aggregation mechanisms at the edge to reduce data volume before transmission to the cloud. Additionally, employing advanced analytics techniques such as machine learning and AI can help identify patterns and anomalies in IoT data more efficiently.

- 3. Cost Management:** Scaling IoT and cloud infrastructure can lead to increased costs, including data storage, bandwidth, and compute resources. To manage costs effectively, implementations should optimize resource utilization, leverage serverless computing models, and implement cost-tracking and monitoring tools to identify areas for optimization. Additionally, exploring pricing models offered by cloud providers, such as reserved instances or spot instances, can help mitigate costs associated with long-term usage.

VIII. FUTURE TRENDS AND DIRECTIONS

Emerging Technologies Impacting IoT and Cloud Integration:

- 1. 5G Networks:** The rollout of 5G networks promises to revolutionize IoT by providing faster and more reliable connectivity. This will enable more devices to connect simultaneously and transmit data in real-time, facilitating seamless integration with cloud platforms.
- 2. Edge Computing:** With the proliferation of IoT devices generating massive amounts of data, there's a growing need to process this data closer to the source to reduce latency and bandwidth usage. Edge computing allows for data processing and analysis to occur closer to where the data is generated, enabling quicker decision-making and response times.
- 3. AI and Machine Learning:** Integrating AI and machine learning capabilities into IoT devices and cloud platforms enables more intelligent data analysis and predictive insights. This can optimize resource utilization, enhance security measures, and improve overall system performance.
- 4. Blockchain:** Blockchain technology offers decentralized and secure data management, which is particularly relevant for IoT applications where data integrity and security are paramount. It can enable transparent and tamper-proof transactions between IoT devices and cloud platforms, enhancing trust and reliability.
- 5. Quantum Computing:** While still in its early stages, quantum computing has the potential to revolutionize IoT and cloud integration by exponentially increasing processing power and enabling complex computations. This could lead to breakthroughs in data encryption, optimization algorithms, and simulation techniques.

Predictions for the Evolution of Interoperability and Standardization:

- 1. Interoperability:** As the IoT ecosystem continues to expand with diverse devices and platforms, there will be a greater emphasis on interoperability standards to ensure seamless communication and integration between different systems. Initiatives like the Open Connectivity Foundation (OCF) and the Industrial Internet Consortium (IIC) are working towards defining common protocols and frameworks for interoperability.
- 2. Standardization:** The development of standardized protocols and frameworks will be crucial for ensuring compatibility, security, and scalability in IoT and cloud integration. Standards bodies such as the Institute of Electrical and Electronics Engineers (IEEE),

International Organization for Standardization (ISO), and Internet Engineering Task Force (IETF) play a vital role in defining and refining these standards.

- 3. Vertical Integration:** There will be a trend towards vertical integration, where industry-specific standards and protocols are developed to address the unique requirements and challenges of different sectors such as healthcare, manufacturing, agriculture, and smart cities. This vertical integration will foster innovation and accelerate the adoption of IoT and cloud technologies in specific domains.
- 4. Security and Privacy Standards:** With the increasing proliferation of connected devices and the growing concerns around data privacy and security, there will be a greater focus on developing robust standards and regulations to safeguard sensitive information and mitigate cybersecurity risks. This includes standards for encryption, authentication, access control, and data governance.

Opportunities for Research and Innovation in the Field:

- 1. Advanced Data Analytics:** There is a vast opportunity for research and innovation in developing advanced analytics techniques for processing and extracting insights from the massive amounts of data generated by IoT devices. This includes machine learning algorithms for anomaly detection, predictive maintenance, and optimization.
- 2. Edge Intelligence:** Research in edge computing and edge intelligence seeks to optimize resource allocation, minimize latency, and enhance decision-making capabilities at the edge of the network. This involves developing lightweight algorithms and models that can run efficiently on resource-constrained edge devices.
- 3. Autonomous Systems:** The convergence of IoT, cloud computing, and AI presents exciting opportunities for research in autonomous systems. This includes autonomous vehicles, drones, robotics, and smart infrastructure that can operate and make decisions autonomously based on real-time data and environmental conditions.
- 4. Privacy-Preserving Technologies:** Addressing concerns around data privacy and security requires innovative solutions for preserving privacy while still enabling data sharing and analysis. Research in techniques such as homomorphic encryption, differential privacy, and federated learning aims to achieve this balance between privacy and utility in IoT and cloud environments.
- 5. Sustainability and Green IoT:** As the environmental impact of technology becomes increasingly evident, there is a growing need for research in sustainable IoT solutions. This includes developing energy-efficient devices, optimizing resource utilization, and designing eco-friendly protocols and algorithms to minimize the carbon footprint of IoT and cloud infrastructures.

IX. FINDING AND DISCUSSION

The research findings the complexities and obstacles present in integrating Internet of Things (IoT) devices with cloud computing systems. Let's break down the outcomes in detail:

- 1. Identification of Critical Challenges:** The research has successfully identified key challenges that hinder interoperability between IoT devices and cloud platforms. These challenges could include issues such as compatibility issues between different protocols used by IoT devices and cloud services, security concerns in data transmission and storage, scalability issues, and lack of standardized communication protocols.
- 2. Examination of Existing Standards:** The study likely delved into the existing standards and protocols governing IoT and cloud integration. This examination helps in understanding the current landscape of interoperability frameworks and identifying gaps or areas for improvement. It could involve analyzing protocols like MQTT, CoAP, or AMQP for IoT communication, and standards like OPC UA or OCF for device interoperability.
- 3. Insights for Overcoming Interoperability Barriers:** By rigorously examining the challenges and existing standards, the research likely offers valuable insights into potential strategies for overcoming interoperability barriers. These insights could include recommendations for developing new standards, enhancing existing protocols, or implementing middleware solutions that facilitate seamless communication between IoT devices and cloud platforms.
- 4. Foundation for Guidelines and Recommendations:** The findings serve as a solid foundation for the development of guidelines and recommendations aimed at promoting interoperability in diverse IoT and cloud environments. These guidelines could provide best practices for system architects, developers, and policymakers to follow when designing and implementing IoT-cloud integration solutions.
- 5. Imperative for Enhanced Interoperability and Standardization:** The research underscores the importance of enhanced interoperability and standardization in IoT and cloud integration. By addressing the identified challenges and proposing viable solutions, stakeholders across industries can benefit significantly. This includes improved efficiency, reduced development costs, enhanced security, and accelerated innovation in IoT and cloud technologies.
- 6. Unlocking Transformative Potential:** Through improved interoperability and standardization, stakeholders can unlock the transformative potential of IoT and cloud technologies. This could lead to the development of innovative applications and services that leverage the combined power of IoT devices and cloud computing, driving digital transformation across various sectors such as healthcare, transportation, manufacturing, and smart cities.

7. Continued Evolution and Standardization: As IoT and cloud ecosystems continue to evolve, establishing robust standards remains paramount. The research emphasizes the ongoing need for collaboration among industry stakeholders, standardization bodies, and regulatory agencies to develop and maintain interoperability frameworks that keep pace with technological advancements and address emerging challenges effectively.

In summary, the outcomes of this research provide valuable insights and recommendations for addressing interoperability challenges in IoT and cloud integration, ultimately paving the way for the widespread adoption and realization of the transformative potential of these technologies.

X. CONCLUSION

In summary, IoT and Cloud Integration involve connecting IoT devices to cloud platforms for data exchange and processing. Key components include IoT devices, cloud platforms, communication protocols, and middleware. Challenges include device diversity, connectivity issues, security concerns, and scalability. Interoperability and standardization efforts are essential for overcoming these challenges and enabling seamless integration across heterogeneous devices and platforms.

In conclusion, interoperability is essential for realizing the full potential of IoT and cloud integration, enabling seamless communication, scalability, and innovation. By embracing standards, implementing robust security measures, and leveraging middleware solutions, organizations can overcome interoperability challenges and build interconnected IoT ecosystems that deliver value and drive digital transformation.

By addressing these challenges and implementing strategies to promote standardization, the IoT industry can achieve greater interoperability, security, and scalability, unlocking the full potential of IoT and cloud integration across diverse applications and domains.

By adhering to these best practices and guidelines, organizations can effectively integrate IoT devices with cloud services while ensuring interoperability, scalability, compatibility, and future-proofing of their solutions.

In conclusion, successful IoT and cloud integration projects leverage real-world examples, lessons learned, and strategies for overcoming challenges to deliver value across various industries. By prioritizing scalability, security, interoperability, and cost-effectiveness, organizations can harness the power of IoT data to drive innovation and achieve their business objectives.

Overall, the future of IoT and cloud integration is ripe with opportunities for technological advancement and innovation, driven by emerging technologies, evolving standards, and the pursuit of addressing societal challenges and industry needs.

References

- 1) Li, S., Da Xu, L., & Zhao, S. (2022). The internet of things: a survey. *Information Systems Frontiers*, 17(2), 243-259.
- 2) Perera, C., Liu, C. H., Jayawardena, S., & Chen, M. (2021). A survey on internet of things from industrial market perspective. *IEEE Access*, 4, 6787-6795.
- 3) Atzori, L., Iera, A., & Morabito, G. (2022). The Internet of Things: A survey. *Computer Networks*, 54(15), 2787-2805.
- 4) Deeba K, O. Rama Devi, Mohammed Saleh Al Ansari, BhargaviPeddi Reddy, Manohara H T, Yousef A. Baker El-Ebiary and ManikandanRengarajan, "Optimizing Crop Yield Prediction in Precision Agriculture with Hyperspectral Imaging-Unmixing and Deep Learning" *International Journal of Advanced Computer Science and Applications(IJACSA)*, 14(12), 2023. <http://dx.doi.org/10.14569/IJACSA.2023.0141261>.
- 5) S. Bamansoor et al., "Evaluation of Chinese Electronic Enterprise from Business and Customers Perspectives," 2021 2nd International Conference on Smart Computing and Electronic Enterprise (ICSCEE), 2021, pp. 169-174, doi: 10.1109/ICSCEE50312.2021.9498093.
- 6) ArtikaFarhana, NimmatiSatheesh, Ramya M, JanjhyamVenkata Naga Ramesh and Yousef A. Baker El-Ebiary, "Efficient Deep Reinforcement Learning for Smart Buildings: Integrating Energy Storage Systems Through Advanced Energy Management Strategies" *International Journal of Advanced Computer Science and Applications(IJACSA)*, 14(12), 2023. <http://dx.doi.org/10.14569/IJACSA.2023.0141257>.
- 7) Altrad et al., "Amazon in Business to Customers and Overcoming Obstacles," 2021 2nd International Conference on Smart Computing and Electronic Enterprise (ICSCEE), 2021, pp. 175-179, doi: 10.1109/ICSCEE50312.2021.9498129. *IEEE Explore, Scopus*
- 8) Ganesh Khekare, K. Pavan Kumar, Kundeti Naga Prasanthi, Sanjiv Rao Godla, VenubabuRachapudi, Mohammed Saleh Al Ansari and Yousef A. Baker El-Ebiary, "Optimizing Network Security and Performance Through the Integration of Hybrid GAN-RNN Models in SDN-based Access Control and Traffic Engineering" *International Journal of Advanced Computer Science and Applications(IJACSA)*, 14(12), 2023. <http://dx.doi.org/10.14569/IJACSA.2023.0141262>.
- 9) Y. A. Baker El-Ebiary et al., "Mobile Commerce and its Apps - Opportunities and Threats in Malaysia," 2021 2nd International Conference on Smart Computing and Electronic Enterprise (ICSCEE), 2021, pp. 180-185, doi: 10.1109/ICSCEE50312.2021.9498228.
- 10) Lakshmi K, SrideviGadde, Murali Krishna Puttagunta, G. Dhanalakshmi and Yousef A. Baker El-Ebiary, "Efficiency Analysis of Firefly Optimization-Enhanced GAN-Driven Convolutional Model for Cost-Effective Melanoma Classification" *International Journal of Advanced Computer Science and Applications(IJACSA)*, 14(11), 2023. <http://dx.doi.org/10.14569/IJACSA.2023.0141175>.
- 11) Zhou, J., Cao, Z., Dong, X., Vasilakos, A. V., & Leung, V. C. M. (2018). Security and privacy for cloud-based IoT: Challenges. *IEEE Communications Magazine*, 56(3), 52-57.
- 12) Botta, A., de Donato, W., Persico, V., & Pescapé, A. (2016). Integration of cloud computing and Internet of Things: A survey. *Future Generation Computer Systems*, 56, 684-700.
- 13) Palattella, M. R., Dohler, M., Grieco, A., Rizzo, G., Torsner, J., & Engel, T. (2016). Internet of things in the 5G era: Enablers, architecture, and business models. *IEEE Journal on Selected Areas in Communications*, 34(3), 510-527. M. B. Mohamad et al., "Enterprise Problems and Proposed Solutions Using the Concept of E-Commerce," 2021 2nd International Conference on Smart Computing and Electronic Enterprise (ICSCEE), 2021, pp. 186-192, doi: 10.1109/ICSCEE50312.2021.9498197.

- 14) G. Kanaan, F. R. Wahsheh, Y. A. B. El-Ebiary, W. M. A. F. Wan Hamzah, B. Pandey and S. N. P, "An Evaluation and Annotation Methodology for Product Category Matching in E-Commerce Using GPT," 2023 International Conference on Computer Science and Emerging Technologies (CSET), Bangalore, India, 2023, pp. 1-6, doi: 10.1109/CSET58993.2023.10346684.
- 15) F. R. Wahsheh, Y. A. Moaiad, Y. A. Baker El-Ebiary, W. M. Amir Fazamin Wan Hamzah, M. H. Yusoff and B. Pandey, "E-Commerce Product Retrieval Using Knowledge from GPT-4," 2023 International Conference on Computer Science and Emerging Technologies (CSET), Bangalore, India, 2023, pp. 1-8, doi: 10.1109/CSET58993.2023.10346860.
- 16) P. R. Pathmanathan et al., "The Benefit and Impact of E-Commerce in Tourism Enterprises," 2021 2nd International Conference on Smart Computing and Electronic Enterprise (ICSCEE), 2021, pp. 193-198, doi: 10.1109/ICSCEE50312.2021.9497947.
- 17) F. H. Zawaideh, W. Abu-Ulbeh, S. A. Mjlae, Y. A. B. El-Ebiary, Y. Al Moaiad and S. Das, "Blockchain Solution For SMEs Cybersecurity Threats In E-Commerce," 2023 International Conference on Computer Science and Emerging Technologies (CSET), Bangalore, India, 2023, pp. 1-7, doi: 10.1109/CSET58993.2023.10346628.
- 18) International Conference on Smart Computing and Electronic Enterprise (ICSCEE), 2021, pp. 199-205, doi: 10.1109/ICSCEE50312.2021.9498175.
- 19) F. H. Zawaideh, W. Abu-ulbeh, Y. I. Majdalawi, M. D. Zakaria, J. A. Jusoh and S. Das, "E-Commerce Supply Chains with Considerations of Cyber-Security," 2023 International Conference on Computer Science and Emerging Technologies (CSET), Bangalore, India, 2023, pp. 1-8, doi: 10.1109/CSET58993.2023.10346738.
- 20) Suresh Babu Jugunta, Manikandan Rengarajan, Sridevi Gadde, Yousef A.Baker El-Ebiary, Veera Ankalu. Vuyyuru, NamrataVerma and FarhatEmbarak, "Exploring the Insights of Bat Algorithm-Driven XGB-RNN (BARXG) for Optimal Fetal Health Classification in Pregnancy Monitoring" International Journal of Advanced Computer Science and Applications(IJACSA), 14(11), 2023.
<http://dx.doi.org/10.14569/IJACSA.2023.0141174>.
- 21) S. M. S. Hilles et al., "Latent Fingerprint Enhancement and Segmentation Technique Based on Hybrid Edge Adaptive DTV Model," 2021 2nd International Conference on Smart Computing and Electronic Enterprise (ICSCEE), 2021, pp. 8-13, doi: 10.1109/ICSCEE50312.2021.9498025.
- 22) Suresh BabuJugunta, Yousef A.Baker El-Ebiary, K. AanandhaSaravanan, Kanakam Siva Rama Prasad, S. Koteswari, VenubabuRachapudi and ManikandanRengarajan, "Unleashing the Potential of Artificial Bee Colony Optimized RNN-Bi-LSTM for Autism Spectrum Disorder Diagnosis" International Journal of Advanced Computer Science and Applications(IJACSA), 14(11), 2023.
<http://dx.doi.org/10.14569/IJACSA.2023.0141173>.
- 23) S. M. S. Hilles et al., "Adaptive Latent Fingerprint Image Segmentation and Matching using Chan-Vese Technique Based on EDTV Model," 2021 2nd International Conference on Smart Computing and Electronic Enterprise (ICSCEE), 2021, pp. 2-7, doi: 10.1109/ICSCEE50312.2021.9497996.
- 24) MoreshMukhedkar, Chamandeep Kaur, DivvelaSrinivasa Rao, Shweta Bandhekar, Mohammed Saleh Al Ansari, MagantiSyamala and Yousef A.Baker El-Ebiary, "Enhanced Land Use and Land Cover Classification Through Human Group-based Particle Swarm Optimization-Ant Colony Optimization Integration with Convolutional Neural Network" International Journal of Advanced Computer Science and Applications(IJACSA), 14(11), 2023.
<http://dx.doi.org/10.14569/IJACSA.2023.0141142>.

- 25) SweetyBakyarani. E, Anil Pawar, SrideviGadde, EswarPatnala, P. Naresh and Yousef A. Baker El-Ebiary, "Optimizing Network Intrusion Detection with a Hybrid Adaptive Neuro Fuzzy Inference System and AVO-based Predictive Analysis" International Journal of Advanced Computer Science and Applications(IJACSA), 14(11), 2023. <http://dx.doi.org/10.14569/IJACSA.2023.0141131>.
- 26) N. A. Al-Sammarraie, Y. M. H. Al-Mayali and Y. A. Baker El-Ebiary, "Classification and diagnosis using back propagation Artificial Neural Networks (ANN)," 2018 International Conference on Smart Computing and Electronic Enterprise (ICSCEE), Shah Alam, Malaysia, 2018, pp. 1-5. 19 November 2018, DOI: 10.1109/ICSCEE.2018.8538383.
- 27) B. Pawar, C Priya, V. V. Jaya Rama Krishnaiah, V. Antony Asir Daniel, Yousef A. Baker El-Ebiary and Ahmed I. Taloba, "Multi-Scale Deep Learning-based Recurrent Neural Network for Improved Medical Image Restoration and Enhancement" International Journal of Advanced Computer Science and Applications(IJACSA), 14(10), 2023. <http://dx.doi.org/10.14569/IJACSA.2023.0141088>.
- 28) Nripendra Narayan Das, SanthakumarGovindasamy, Sanjiv Rao Godla, Yousef A.Baker El-Ebiary and E.Thenmozhi, "Utilizing Deep Convolutional Neural Networks and Non-Negative Matrix Factorization for Multi-Modal Image Fusion" International Journal of Advanced Computer Science and Applications(IJACSA), 14(9), 2023. <http://dx.doi.org/10.14569/IJACSA.2023.0140963>.
- 29) MoreshMukhedkar, DivyaRohatgi, VeeraAnkaluVuyyuru, K V S S Ramakrishna, Yousef A.Baker El-Ebiary and V. Antony Asir Daniel, "Feline Wolf Net: A Hybrid Lion-Grey Wolf Optimization Deep Learning Model for Ovarian Cancer Detection" International Journal of Advanced Computer Science and Applications(IJACSA), 14(9), 2023. <http://dx.doi.org/10.14569/IJACSA.2023.0140962>.
- 30) N. V. Rajasekhar Reddy, Araddhana Arvind Deshmukh, VudaSreenivasa Rao, Sanjiv Rao Godla, Yousef A.Baker El-Ebiary, Liz Maribel Robladillo Bravo and R. Manikandan, "Enhancing Skin Cancer Detection Through an AI-Powered Framework by Integrating African Vulture Optimization with GAN-based Bi-LSTM Architecture" International Journal of Advanced Computer Science and Applications(IJACSA), 14(9), 2023. <http://dx.doi.org/10.14569/IJACSA.2023.0140960>.
- 31) Maddikera Krishna Reddy, J. C. Sekhar, VudaSreenivasa Rao, Mohammed Saleh Al Ansari, Yousef A.Baker El-Ebiary, JarubulaRamou and R. Manikandan, "Image Specular Highlight Removal using Generative Adversarial Network and Enhanced Grey Wolf Optimization Technique" International Journal of Advanced Computer Science and Applications(IJACSA), 14(6), 2023. <http://dx.doi.org/10.14569/IJACSA.2023.0140668>.
- 32) K. Sundaramoorthy, R. Anitha, S. Kayalvili, AyatFawzy Ahmed Ghazala, Yousef A.Baker El-Ebiary and Sameh Al-Ashrawy, "Hybrid Optimization with Recurrent Neural Network-based Medical Image Processing for Predicting Interstitial Lung Disease" International Journal of Advanced Computer Science and Applications(IJACSA), 14(4), 2023. <http://dx.doi.org/10.14569/IJACSA.2023.0140462>.
- 33) Yousef MethkalAbdAlgani, B. Nageswara Rao, Chamandeep Kaur, B. Ashreetha, K. V. DayaSagar and Yousef A. Baker El-Ebiary, "A Novel Hybrid Deep Learning Framework for Detection and Categorization of Brain Tumor from Magnetic Resonance Images" International Journal of Advanced Computer Science and Applications(IJACSA), 14(2), 2023. <http://dx.doi.org/10.14569/IJACSA.2023.0140261>.
- 34) Y. A. Baker El-Ebiary et al., "Blockchain as a decentralized communication tool for sustainable development," 2021 2nd International Conference on Smart Computing and Electronic Enterprise (ICSCEE), 2021, pp. 127-133, doi: 10.1109/ICSCEE50312.2021.9497910.
- 35) Ravi Prasad, DudekulaSiddaiah, Yousef A.Baker El-Ebiary, S. Naveen Kumar, K Selvakumar "Forecasting Electricity Consumption Through A Fusion Of Hybrid Random Forest Regression And Linear Regression Models Utilizing Smart Meter Data" Journal of Theoretical and Applied Information Technology, Vol. 101. No. 21 (2023).

- 36) Franciskus Antonius, Purnachandra Rao Alapati, MahyudinRitonga, IndrajitPatra, Yousef A. Baker El-Ebiary, MyagmarsurenOrosoo and ManikandanRengarajan, "Incorporating Natural Language Processing into Virtual Assistants: An Intelligent Assessment Strategy for Enhancing Language Comprehension" International Journal of Advanced Computer Science and Applications(IJACSA), 14(10), 2023. <http://dx.doi.org/10.14569/IJACSA.2023.0141079>.
- 37) Y. A. Baker El-Ebiary et al., "Track Home Maintenance Business Centers with GPS Technology in the IR 4.0 Era," 2021 2nd International Conference on Smart Computing and Electronic Enterprise (ICSCEE), 2021, pp. 134-138, doi: 10.1109/ICSCEE50312.2021.9498070.
- 38) Venkateswara Rao Naramala, B. Anjaneer Kumar, VudaSreenivasa Rao, Annapurna Mishra, Shaikh Abdul Hannan, Yousef A.Baker El-Ebiary and R. Manikandan, "Enhancing Diabetic Retinopathy Detection Through Machine Learning with Restricted Boltzmann Machines" International Journal of Advanced Computer Science and Applications(IJACSA), 14(9), 2023. <http://dx.doi.org/10.14569/IJACSA.2023.0140961>.
- 39) K. N. Preethi, Yousef A. Baker El-Ebiary, Esther Rosa Saenz Arenas, Kathari Santosh, Ricardo Fernando CosioBorda, Jorge L. Javier Vidalón, Anuradha. S and R. Manikandan, "Enhancing Startup Efficiency: Multivariate DEA for Performance Recognition and Resource Optimization in a Dynamic Business Landscape" International Journal of Advanced Computer Science and Applications (IJACSA), 14(8), 2023. <http://dx.doi.org/10.14569/IJACSA.2023.0140869>.
- 40) Atul Tiwari, Shaikh Abdul Hannan, RajasekharPinnamaneni, Abdul Rahman Mohammed Al-Ansari, Yousef A.Baker El-Ebiary, S. Prema, R. Manikandan and Jorge L. Javier Vidalón, "Optimized Ensemble of Hybrid RNN-GAN Models for Accurate and Automated Lung Tumour Detection from CT Images" International Journal of Advanced Computer Science and Applications (IJACSA), 14(7), 2023. <http://dx.doi.org/10.14569/IJACSA.2023.0140769>.
- 41) S. I. Ahmad Saany et al., "Exploitation of a Technique in Arranging an Islamic Funeral," 2021 2nd International Conference on Smart Computing and Electronic Enterprise (ICSCEE), 2021, pp. 1-8, doi: 10.1109/ICSCEE50312.2021.9498224.
- 42) Y. M. A. Tarshany, Y. Al Moaiad and Y. A. Baker El-Ebiary, "Legal Maxims Artificial Intelligence Application for Sustainable Architecture And Interior Design to Achieve the Maqasid of Preserving the Life and Money," 2022 Engineering and Technology for Sustainable Architectural and Interior Design Environments (ETSAIDE), 2022, pp. 1-4, doi: 10.1109/ETSAIDE53569.2022.9906357.
- 43) J. A. Jusoh et al., "Track Student Attendance at a Time of the COVID-19 Pandemic Using Location-Finding Technology," 2021 2nd International Conference on Smart Computing and Electronic Enterprise (ICSCEE), 2021, pp. 147-152, doi: 10.1109/ICSCEE50312.2021.9498043.
- 44) Y. A. Baker El-Ebiary et al., "E-Government and E-Commerce Issues in Malaysia," 2021 2nd International Conference on Smart Computing and Electronic Enterprise (ICSCEE), 2021, pp. 153-158, doi: 10.1109/ICSCEE50312.2021.9498092.
- 45) S. T. Meraj et al., "A Diamond Shaped Multilevel Inverter with Dual Mode of Operation," in IEEE Access, vol. 9, pp. 59873-59887, 2021, doi: 10.1109/ACCESS.2021.3067139.
- 46) Mohammad Kamrul Hasan, Muhammad Shafiq, Shayla Islam, Bishwajeet Pandey, Yousef A. Baker El-Ebiary, Nazmus Shaker Nafi, R. Ciro Rodriguez, Doris Esenarro Vargas, "Lightweight Cryptographic Algorithms for Guessing Attack Protection in Complex Internet of Things Applications", Complexity, vol. 2021, Article ID 5540296, 13 pages, 2021. <https://doi.org/10.1155/2021/5540296>.
- 47) Y. A. B. El-Ebiary et al., "Determinants of Customer Purchase Intention Using Zalora Mobile Commerce Application," 2021 2nd International Conference on Smart Computing and Electronic Enterprise (ICSCEE), 2021, pp. 159-163, doi: 10.1109/ICSCEE50312.2021.9497995.

- 48) S. Bamansoor et al., "Efficient Online Shopping Platforms in Southeast Asia," 2021 2nd International Conference on Smart Computing and Electronic Enterprise (ICSCEE), 2021, pp. 164-168, doi: 10.1109/ICSCEE50312.2021.9497901.
- 49) Ghanem W.A.H.M. et al. (2021) Metaheuristic Based IDS Using Multi-Objective Wrapper Feature Selection and Neural Network Classification. In: Anbar M., Abdullah N., Manickam S. (eds) Advances in Cyber Security. ACeS 2020. Communications in Computer and Information Science, vol 1347. Springer, Singapore. https://doi.org/10.1007/978-981-33-6835-4_26
- 50) Y. A. B. El-Ebiary, S. Almandeel, W. A. H. M. Ghanem, W. Abu-Ulbeh, M. M. M. Al-Dubai and S. Bamansoor, "Security Issues and Threats Facing the Electronic Enterprise Leadership," 2020 International Conference on Informatics, Multimedia, Cyber and Information System (ICIMCIS), 2020, pp. 24-28, doi: 10.1109/ICIMCIS51567.2020.9354330.
- 51) Y. A. B. El-Ebiary, "The Effect of the Organization Factors, Technology and Social Influences on E-Government Adoption in Jordan," 2018 International Conference on Smart Computing and Electronic Enterprise (ICSCEE), Shah Alam, Malaysia, 2018, pp. 1-4. 19 November 2018, DOI: 10.1109/ICSCEE.2018.8538394.
- 52) Borgia, E. (2014). The Internet of Things vision: Key features, applications and open issues. *Computer Communications*, 54, 1-31.
- 53) Jin, J., Gubbi, J., Marusic, S., &Palaniswami, M. (2019). An information framework for creating a smart city through internet of things. *IEEE Internet of Things Journal*, 1(2), 112-121.
- 54) Vermesan, O., &Friess, P. (Eds.). (2019). *Internet of things: converging technologies for smart environments and integrated ecosystems*. River Publishers.
- 55) Shi, W., Cao, J., Zhang, Q., Li, Y., & Xu, L. (2019). Edge computing: Vision and challenges. *IEEE Internet of Things Journal*, 3(5), 637-646.
- 56) Jara, A. J., Zamora, M. A., & Skarmeta, A. F. (2018). Interconnection framework for mHealth and remote monitoring based on the Internet of Things. *IEEE Journal on Selected Areas in Communications*, 31(9), 47-65.
- 57) Ranjan, R., &Paprzycki, M. (2020). Internet of Things (IoT): A vision, architectural elements, and future directions. *Future Generation Computer Systems*, 49, 173-190.
- 58) Gubbi, J., Buyya, R., Marusic, S., &Palaniswami, M. (2019). Internet of Things (IoT): A vision, architectural elements, and future directions. *Future Generation Computer Systems*, 29(7), 1645-1660.
- 59) Yi, S., Hao, Z., Qin, Z., Li, Q., & Li, F. Y. (2019). Fog computing: Platform and applications. In *Proceedings of the 2015 Workshop on Mobile Big Data* (pp. 37-42). ACM.
- 60) Vögler, M., Zibuschka, J., Käbisch, S., & Grießnig, G. (2019). A fog-based platform for end-to-end IoT-Cloud interoperability. In *2017 IEEE International Conference on Edge Computing (EDGE)* (pp. 1-8). IEEE.
- 61) Nastic, S., Sehic, S., &Dustdar, S. (2020). Cloud-of-Things: Unified interoperability framework for IoT platforms. *IEEE Cloud Computing*, 4(2), 20-28.
- 62) Jazdi, N. (2014). Cyber physical systems in the context of Industry 4.0. In *2014 IEEE International Conference on Automation, Quality and Testing, Robotics* (pp. 1-4). IEEE.
- 63) Kamilaris, A., Fonts, A., &Pitsillides, A. (2022). The rise of blockchain technology in agriculture and food supply chains. *Trends in Food Science & Technology*, 91, 640-652.